

**SOCIEDAD CUBANA PARA LA PROMOCIÓN DE LAS FUENTES  
RENOVABLES DE ENERGÍA Y EL RESPETO AMBIENTAL (CUBASOLAR)  
CENTRO DE GESTIÓN DE LA INFORMACIÓN Y DESARROLLO DE LA  
ENERGÍA (CUBAENERGÍA)**

**CONSOLFOOD 2018**

**Develop of Solar Dryers, Cuban Experience for  
Food Preservation.**

Manager of Solar Energy Group: Ing. Boris A. Zaldívar Núñez  
Psychology Specialist: Lic. Glensy Palay Alonso

# Drying

- It represents one of the most efficient and economical ways of solar energy use.
- It is an operation that is widely used in industrial processes, in construction materials manufacturing, food industry, in many cases, with large energy consumption.
- It has a singular importance in conservation of agricultural and marine products.



# Criteria and Definitions

- Drying is the process of decreasing the humidity to a product, by the evaporation and elimination of the water contained in it, without altering its chemical composition. It can be a natural or artificial process.

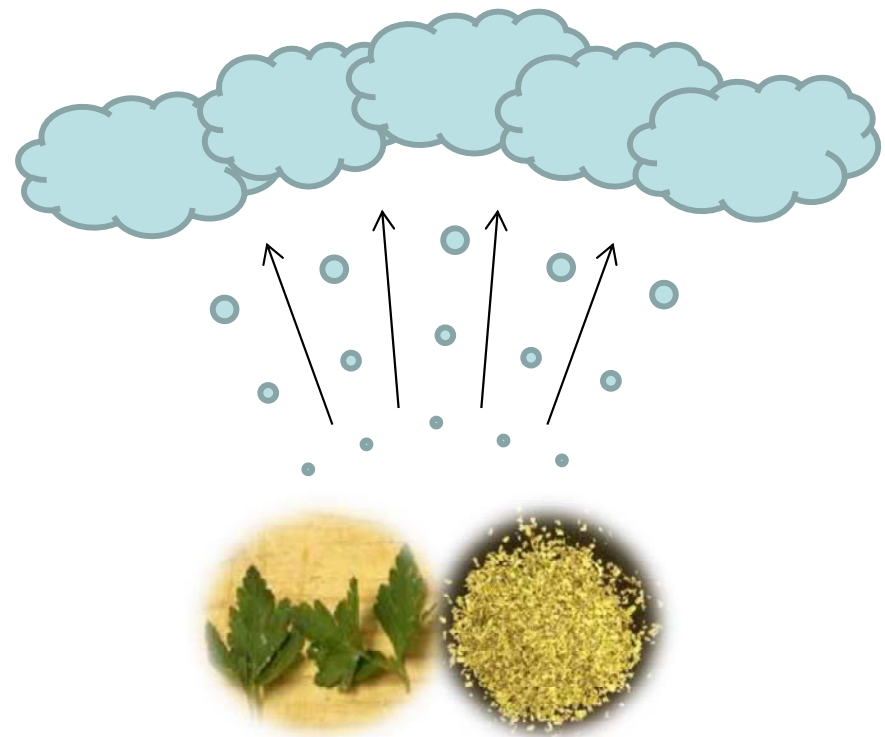

# Criteria and Definitions

- It is known like natural drying, the loss of moisture of products or materials under environmental conditions
- The natural drying of agricultural and industrial products is a widely used process, even in the present.
- In Cuba, natural drying of wood, coffee, cocoa, coconut, corn, rice, seeds, minerals and other products is traditional.



# Criteria and Definitions

- It is called artificial drying to the controlled loss of moisture of products or materials with the use of special equipment or devices.
- For different reasons, artificial drying or dehydration has replaced natural drying in many cases, and this technique is developed more and more.



# Artificial drying

## Advantage

Generally superior product quality, using good process technology.

Higher drying speed with good quality at lower cost.

Sanitary and nutritious food conditions are better, (product not exposed)

The area used in dehydration is smaller.

Simpler dehydration operations, and can have a high degree of automation.

## Disadvantages (non-solar drying)

High installation cost, for the drying chamber and for the boiler, furnaces, or air heaters.

High production cost, in case you consume oil or electricity for heating the air and the product.

With the advance of science and technology in Cuba, different types of solar dryers have been developed, with most of the advantages of conventional dehydrators, without consuming energy for heating the air or the product.

The following section show some examples of dryers developed by genSolar.

# Dryer by trays, greenhouse type

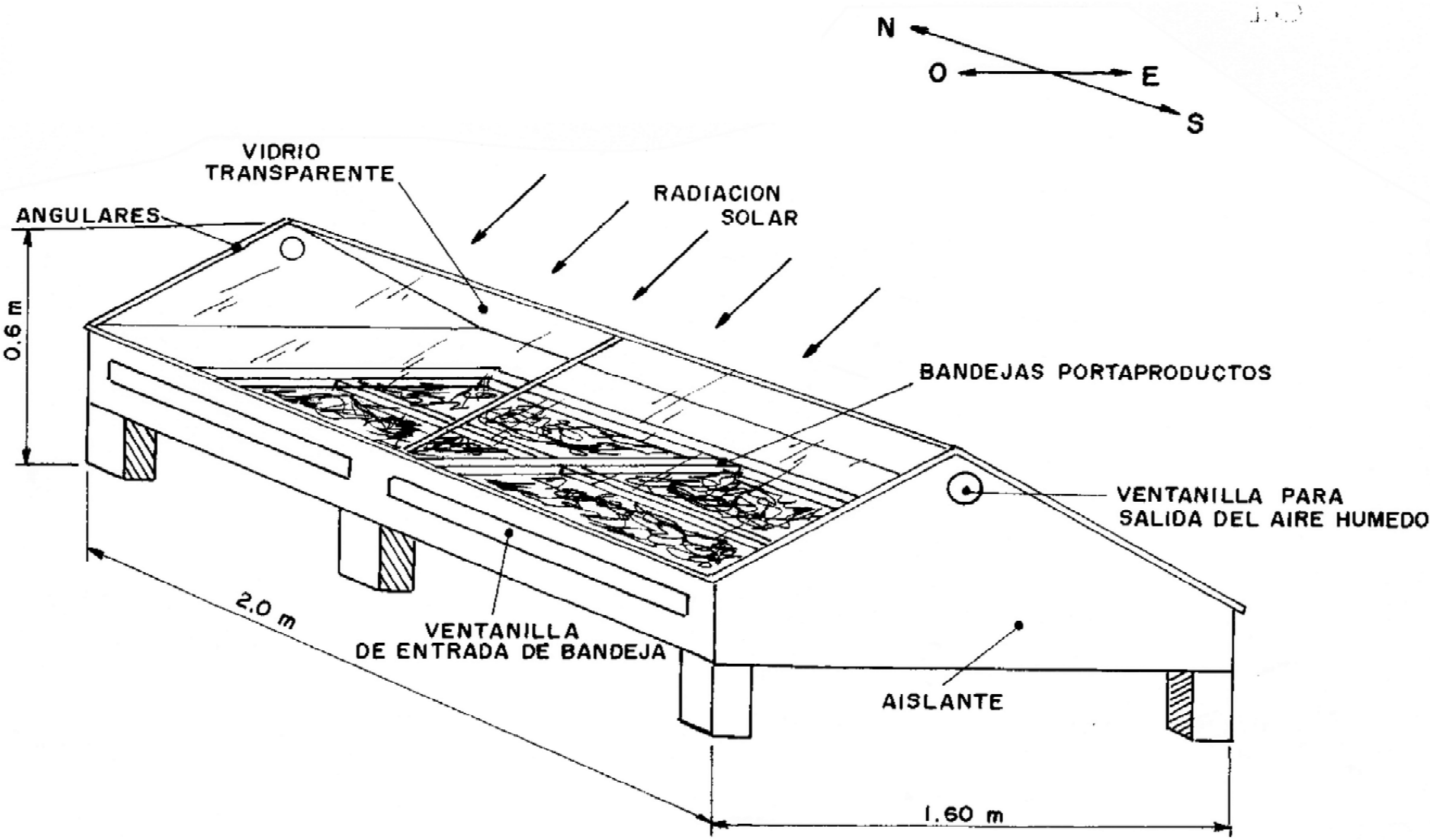



# Experimental model of greenhouse dryer



# Dried peanuts, papaya and mango



# Solar mats dryer

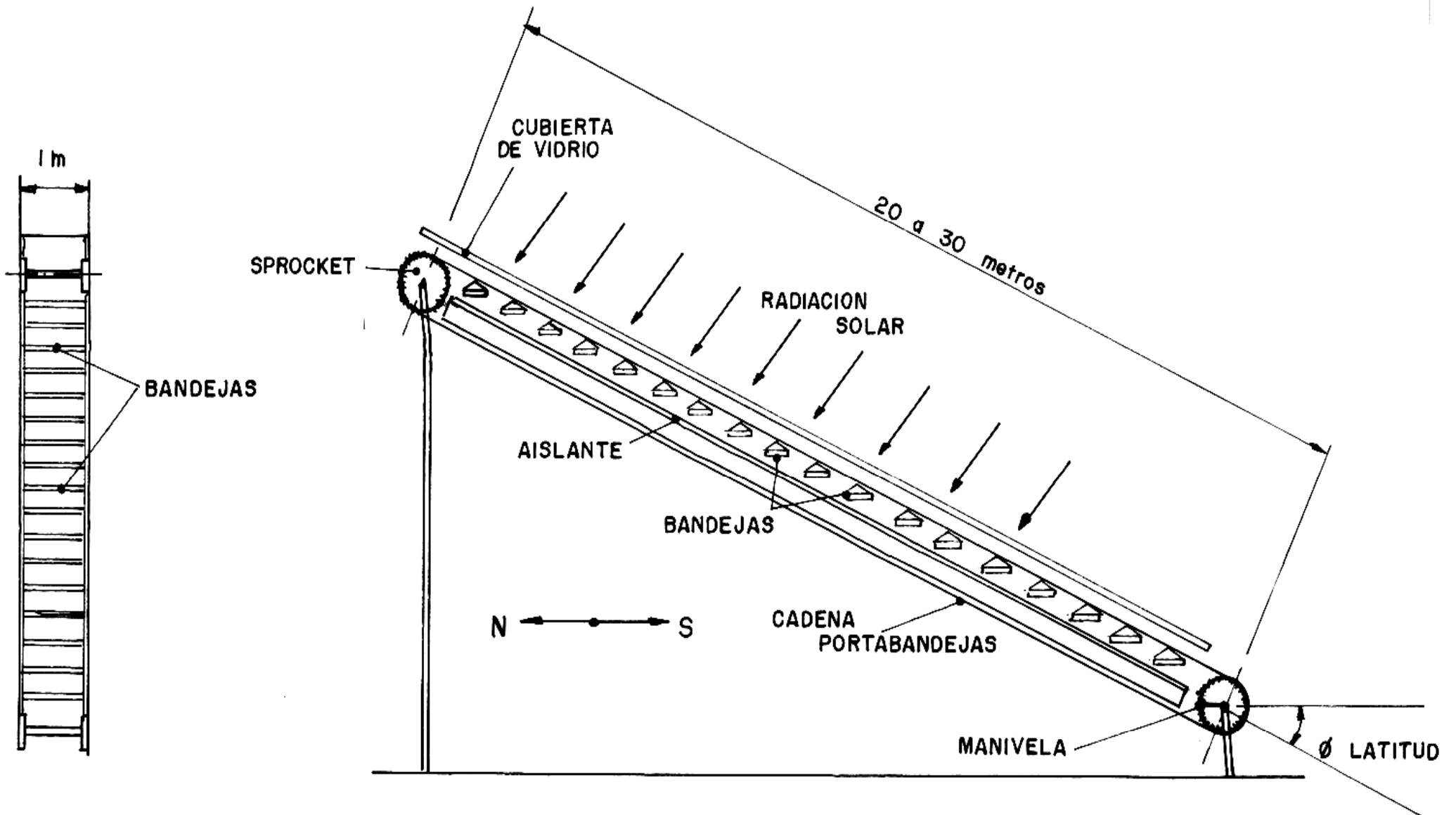

# Solar stove for laboratory and spherical dryer

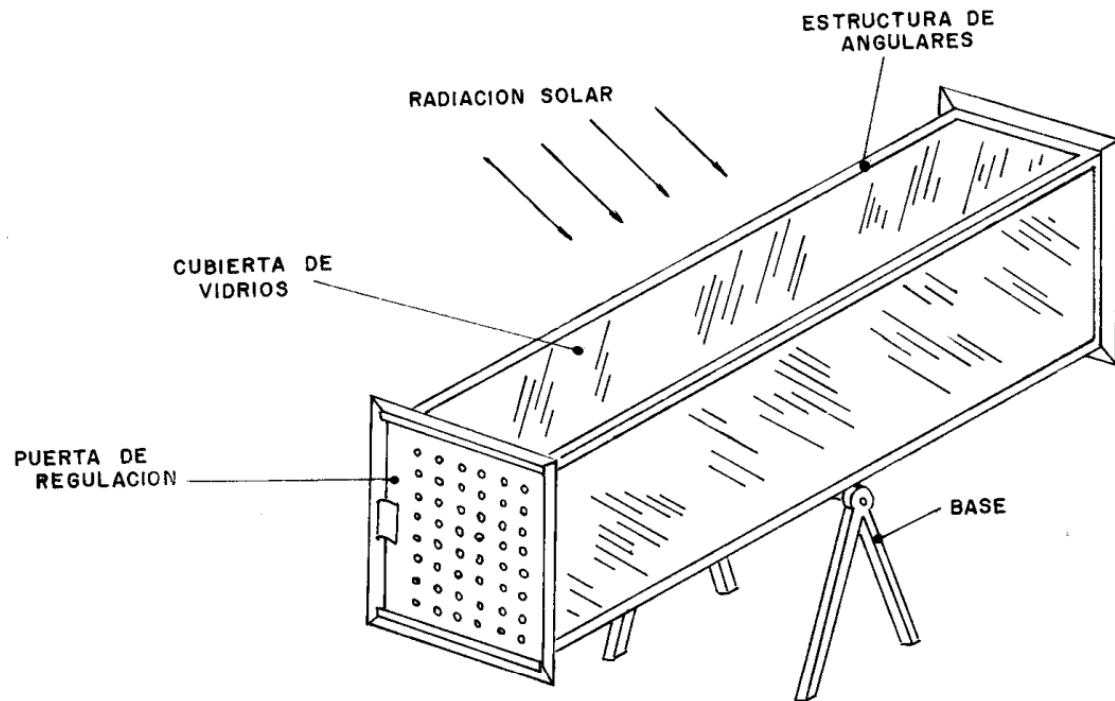
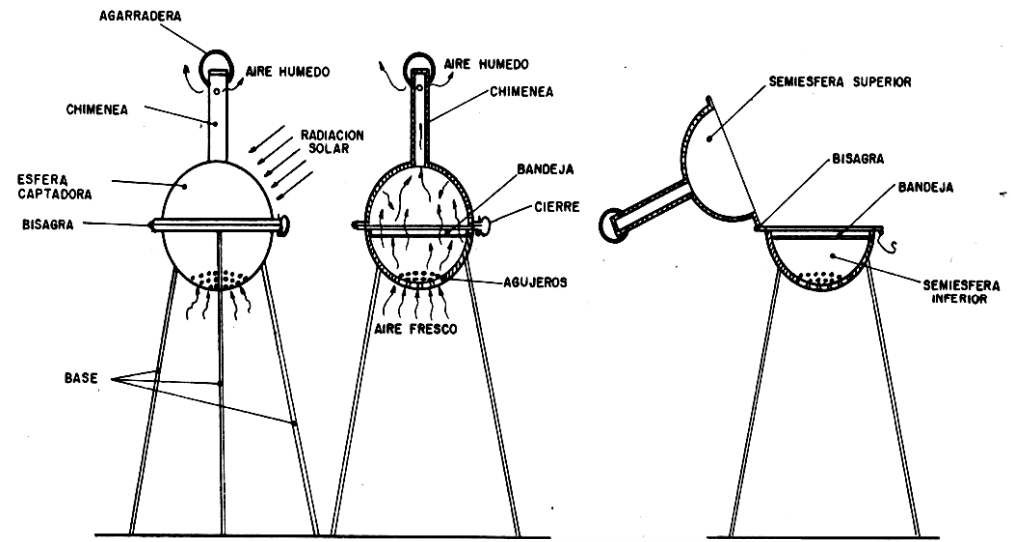
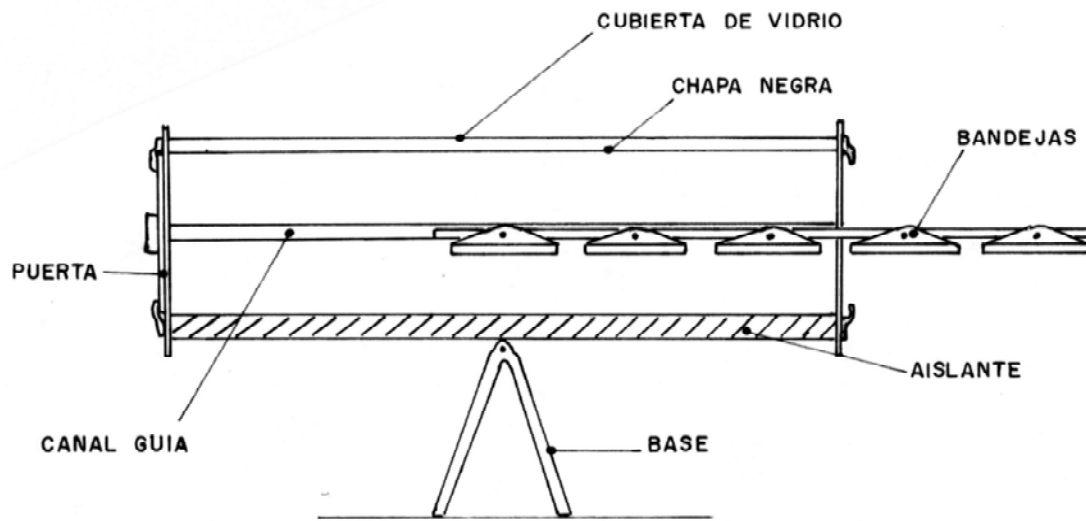

# Drying chamber with air heater with natural circulation.

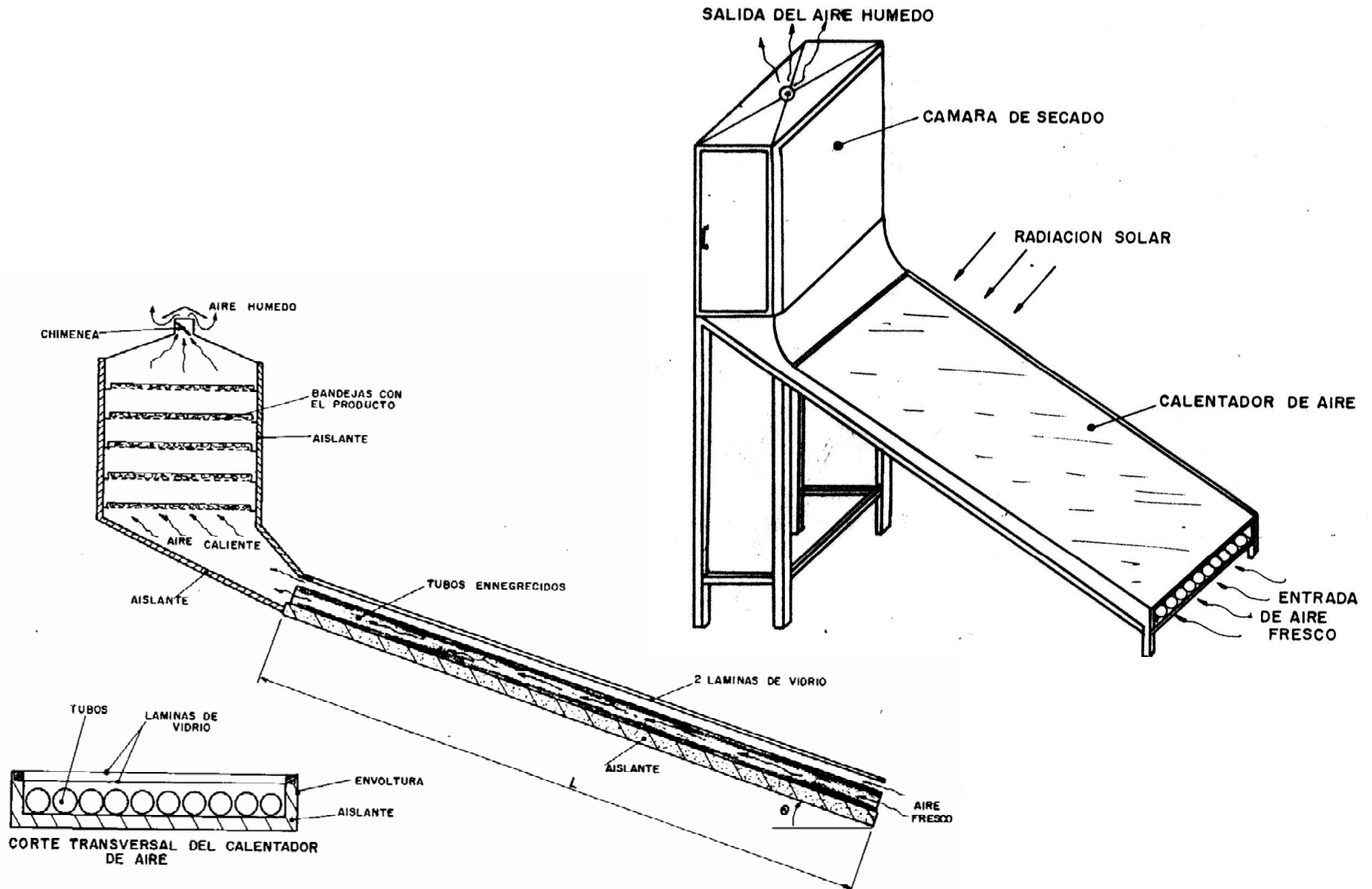

# Drying chamber for installation with solar air heaters

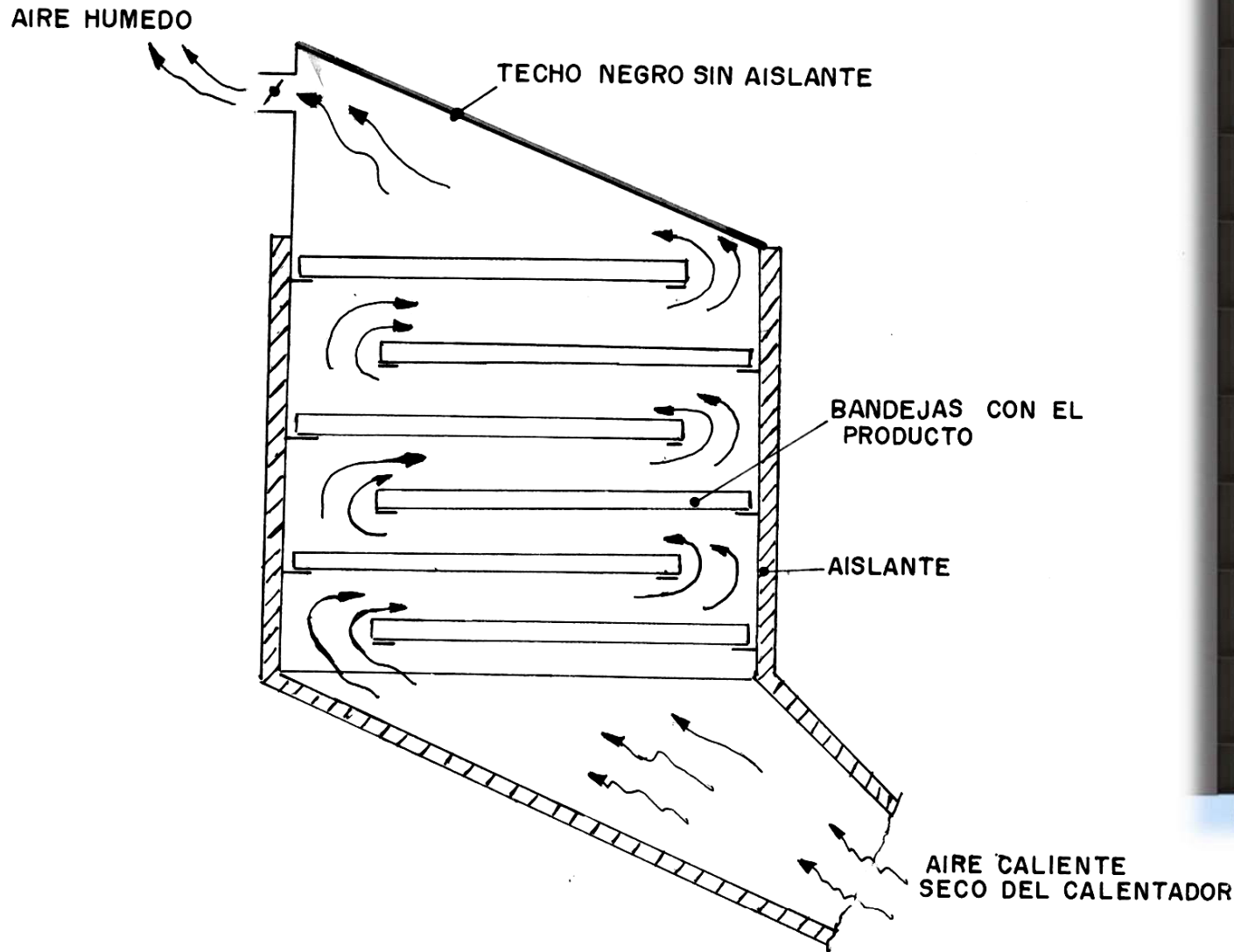

# Cross section of different models of air heaters

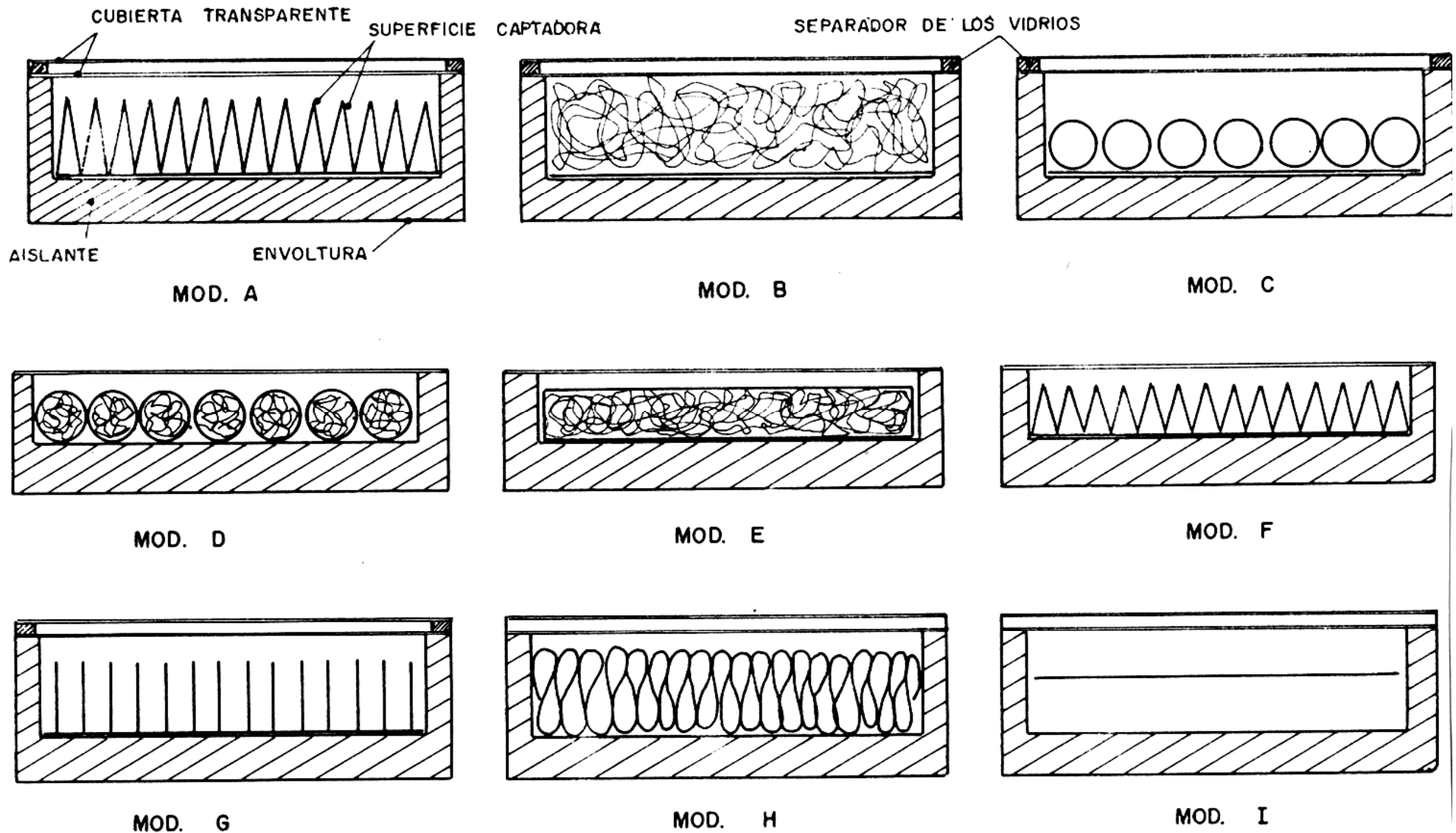

# Solar dryer using drying chambers

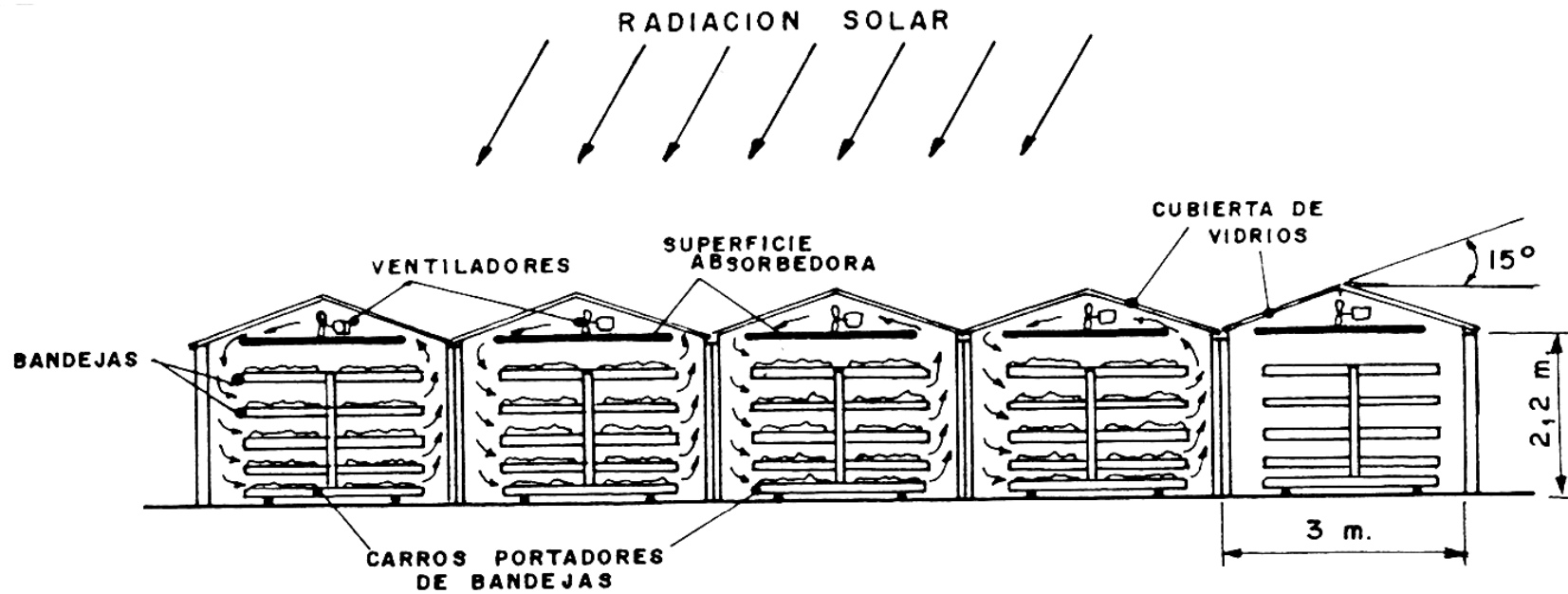



# Dryer of Wajay



# 3-chambers dryer



# Solar dryer of Ciudad Escolar “Camilo Cienfuegos”



# Rotary drum in to drying chamber

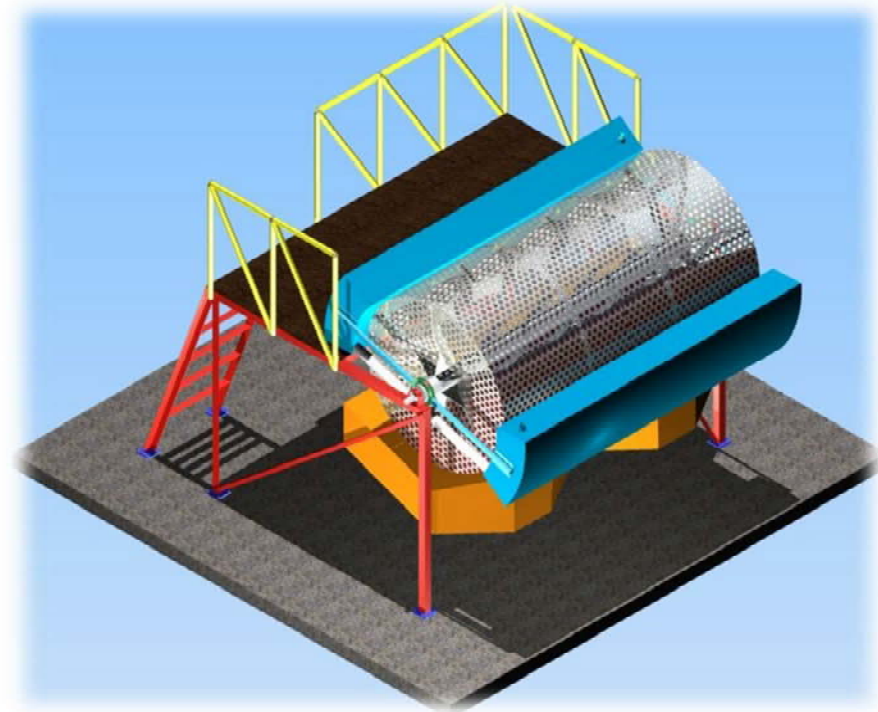
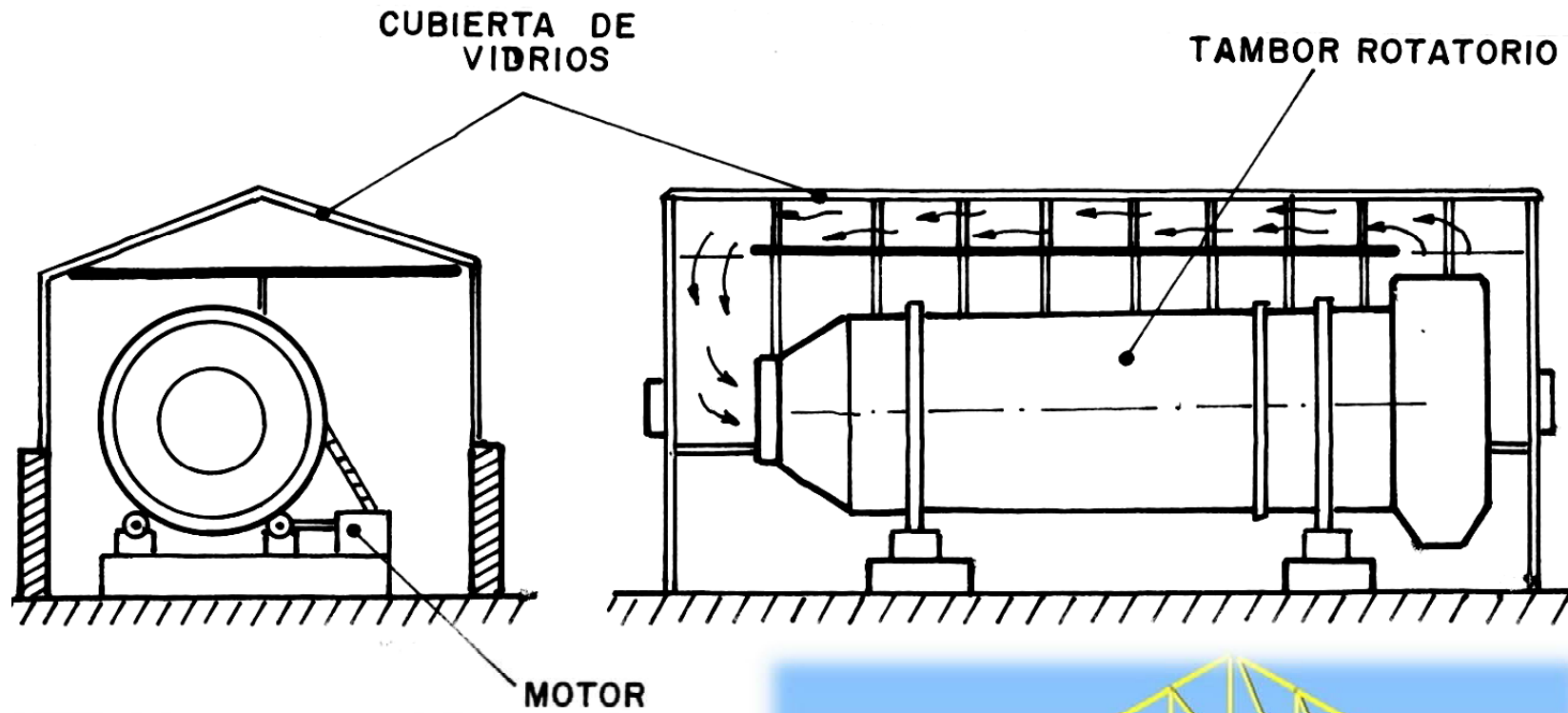

# Solar dryer of fly larvae

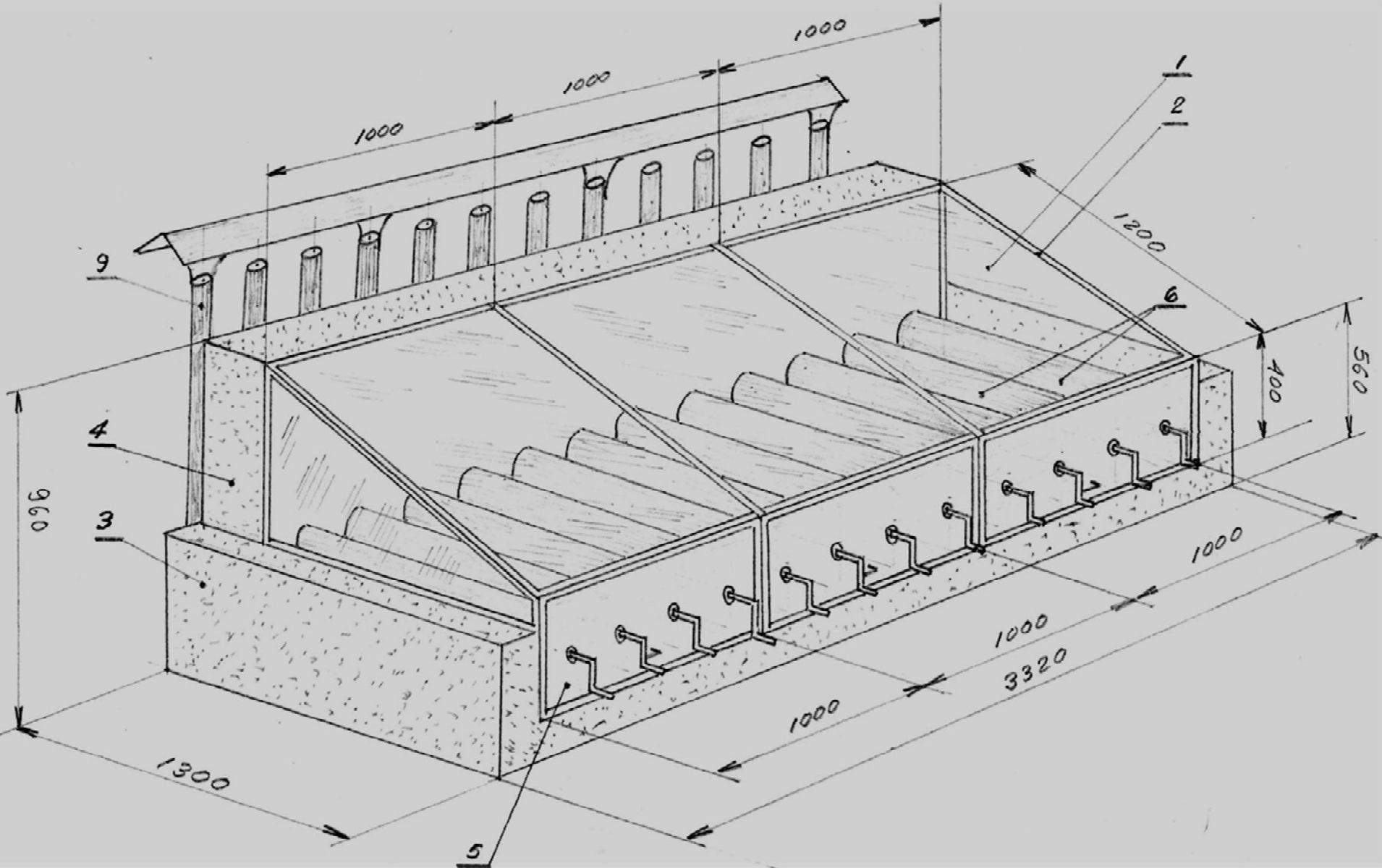

# Wood dryer developed by gen SOLAR and the CIES in 1984

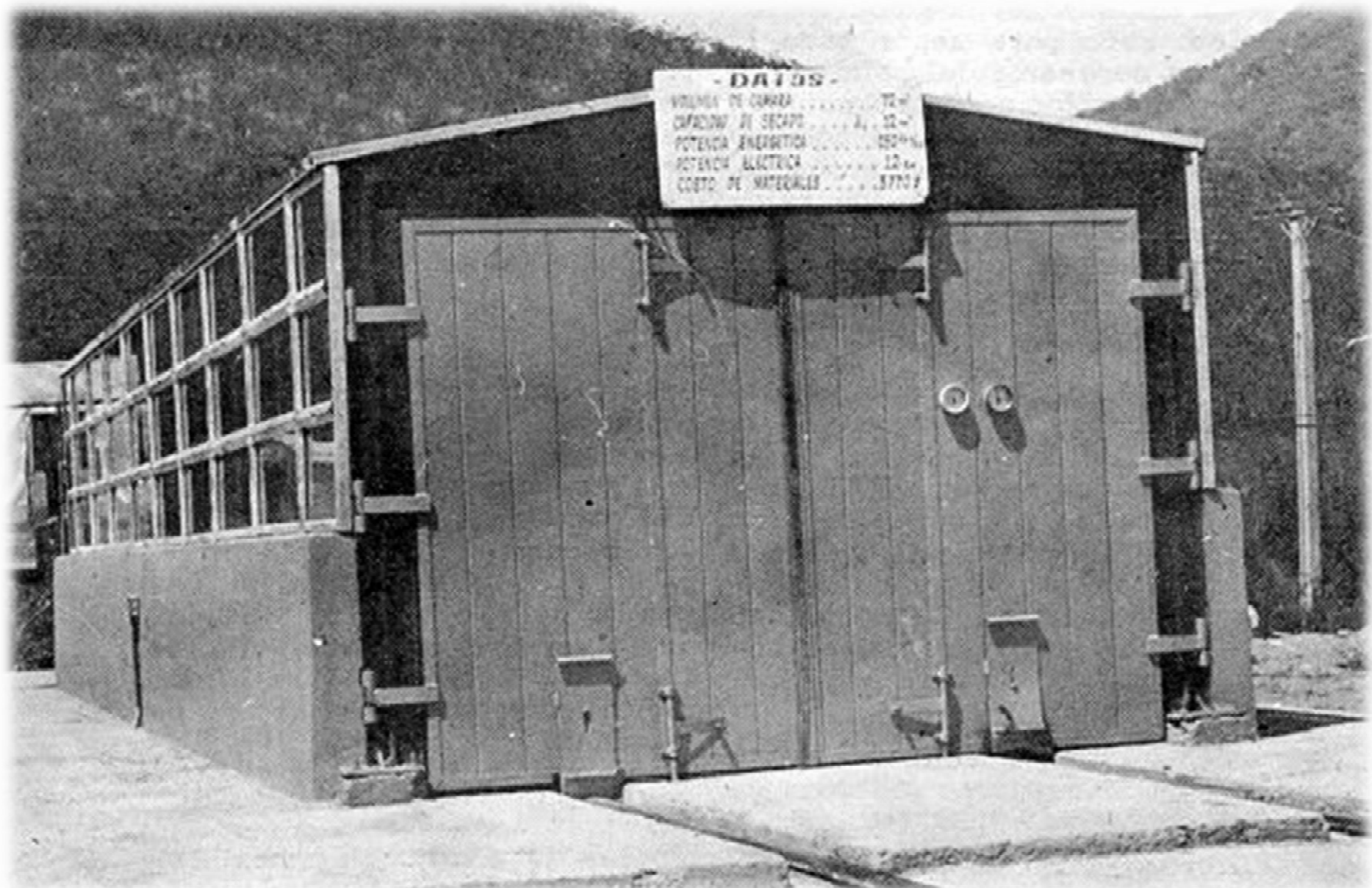

# Drying of wood in a conventional dryer

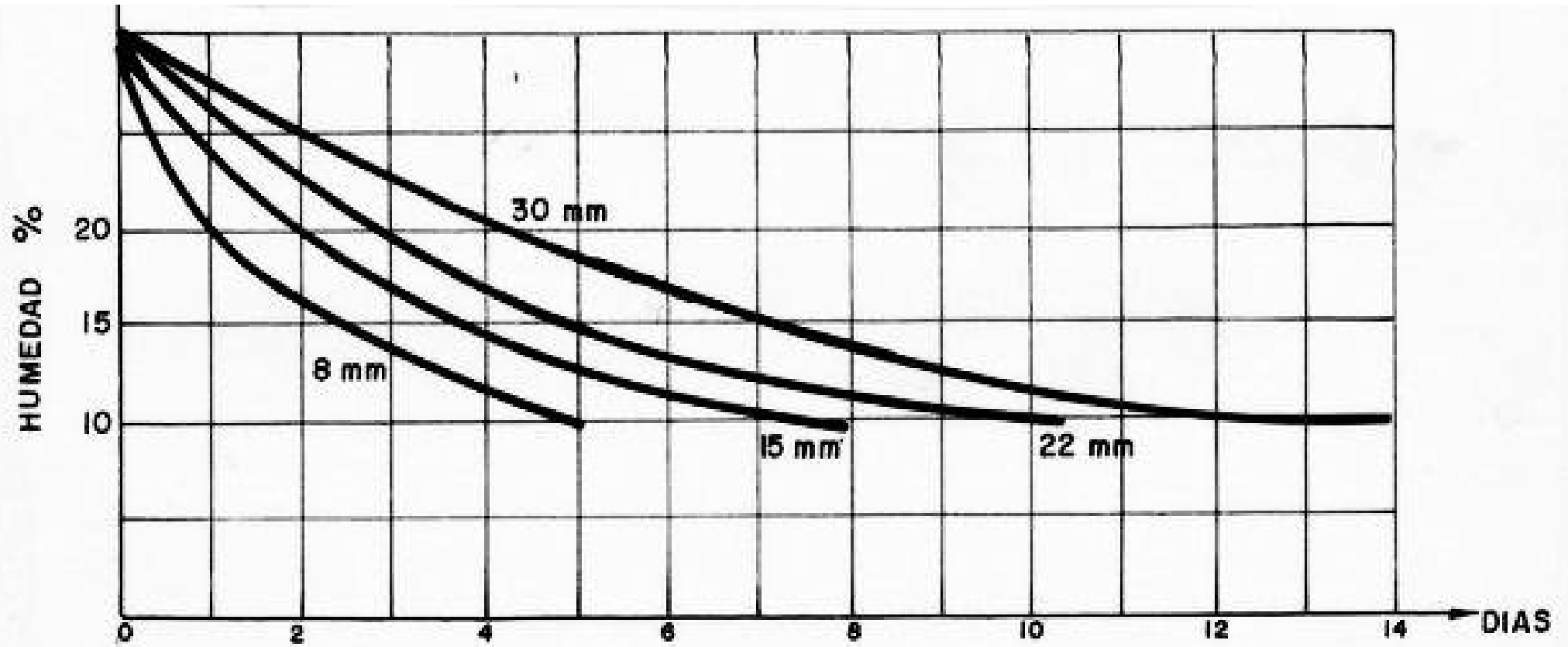

EXPERIMENTO DE SECADO DE TABLAS DE PINO EN UN SECADOR DE PETRÓLEO

# Variation of wood moisture in a solar dryer

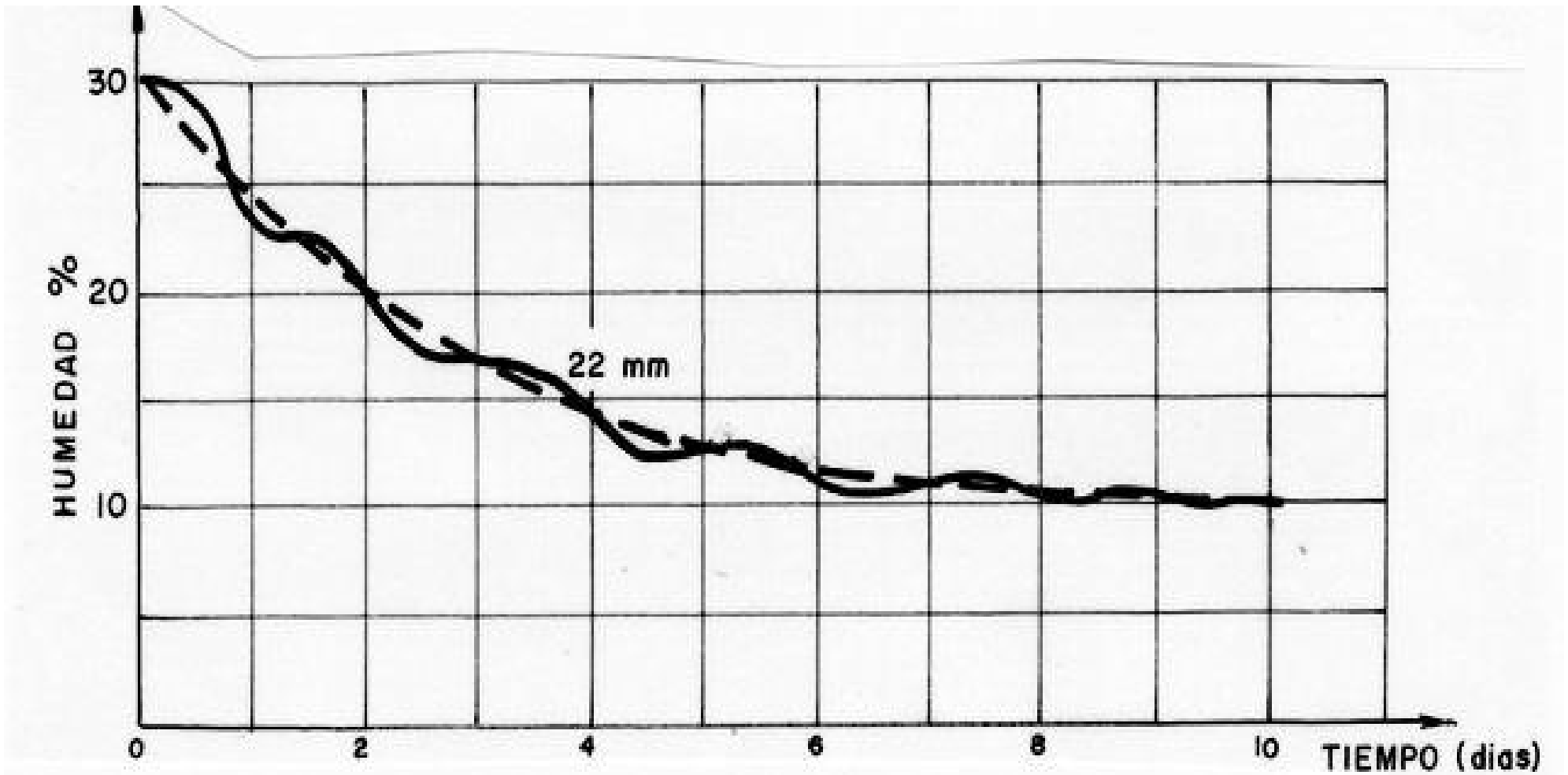



# Solar wood dryer in Mil Cumbres, Pinar del Río













# Experience of the (CNA) Industrias Purita



## Social development

- This is a novel business in Cuba. Alternative seasoned for the social development.
- The social development of Purita's is evident in the educations for childrens and leadership of women.
- This cooperative is based in solidary economy and the citizen responsibility.



# Social development

For example:

- ✓ The products is made in Cuba, with cuban technology, cuban recourses and local material.
- ✓ Promotes sovereignty and food security
- ✓ Women represent the leadership of the factory
- ✓ They are educating infants in the factory development process.

# "The selections and improvement"



# "Dehydration and drying"



# "Dehydration and drying"



# “Molinado”



# "The container"



# Products developed by Industrias Purita





**iii Thank you very  
much!!!**